

FIBREFLOW COOLING TOWERS

FIBREGLASS COUNTERFLOW UNIT DIMENSIONS

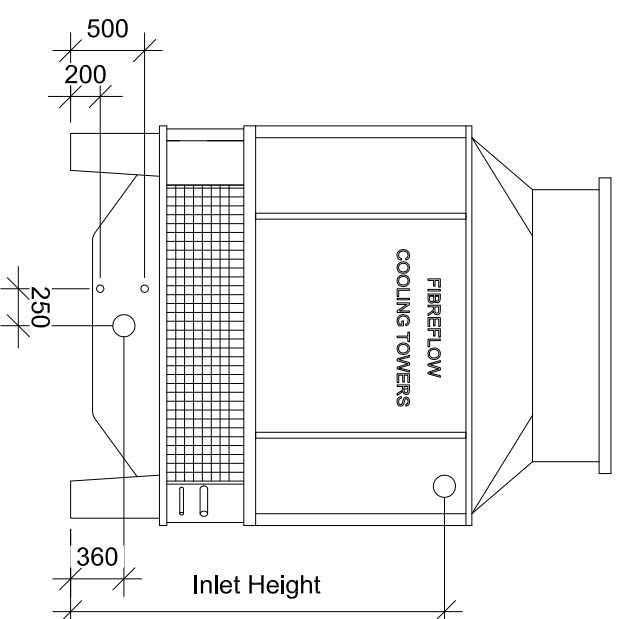
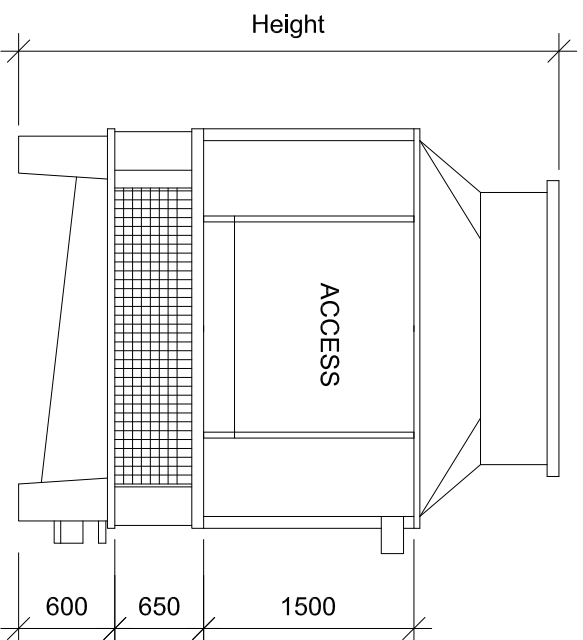
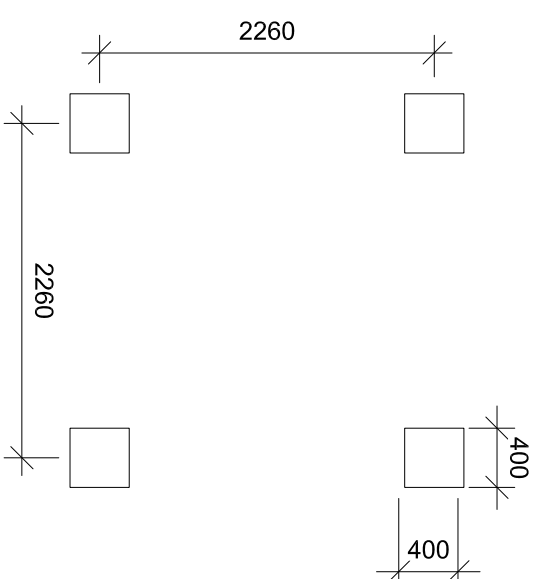
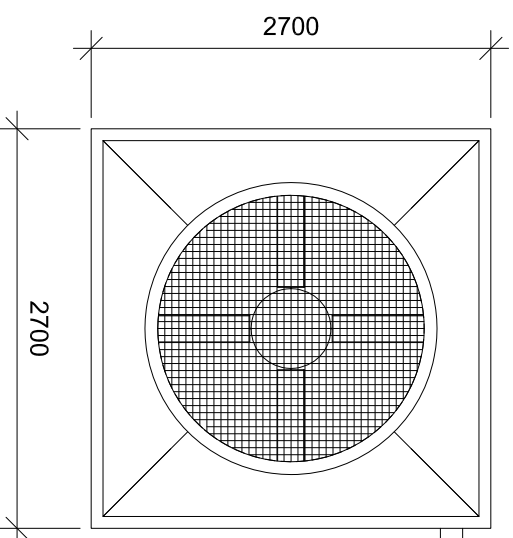

- NOTES:**
1. Minimum plinth height 300mm.
 2. Pipework not to be supported from unit or connections.
 3. Ductwork not to be supported from unit.
 4. Dimension in millimeters, weights in kilograms.
 5. Keep area above fan discharge clear.
 6. Not for production. Refer factory for certified dimensions.
 7. Minimum pressure at inlet connection 25 kPa.
 8. Maximum pressure at makeup water connection 200kPa.

Model Number	Height mm	Inlet Height mm	Fan Diameter mm	Shipping Weight kg	Operating Weight kg	Motor Size kW	Motor Amps	Airflow m ³ /s
CTCF 070A	3730	2500	1830	1200	3500	4	10	16.7
CTCF 078A	3730	2500	1830	1227	3527	5.5	13.5	18.47
CTCF 091A	3730	2500	1830	1321	3737	7.5	17.1	18.97
CTCF 098A	3730	2500	1830	1285	3585	11	25.1	22.85